

## Accessory

# HY-8-101

Capacity	Model
0.5t-3t	HY-8-101-0.5/3t
5t	HY-8-101-5t
10t-15t	HY-8-101-10/5t
20t-25t	HY-8-101-10/25t
30t	HY-8-101-30t
50t	HY-8-101-50t

### Features:

Easy installation, anti-corrosion, non-downable structure, good self-aligning ability. Mainly used for truck scales, platform scales and other electronic weighing devices.



### Outline Dimension mm(inch)

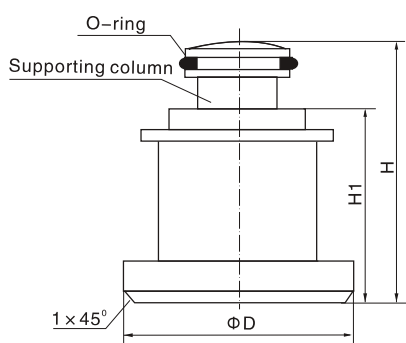

Dimension Capacity	ΦD	H	H1
0.5t-3t	35(1.38)	44.9(1.77)	24.9(0.98)
5t	42(1.65)	56.7(2.23)	34.7(1.37)
10t-15t	57(2.24)	80.7(3.18)	66.7(2.63)
20t-25t	70(2.76)	85(3.35)	67(2.64)
30t	70(2.76)	91(3.58)	70(2.76)
50t	85(3.35)	102(4.04)	82(3.23)

# HY-8-102

Capacity	Part number
0.5t-2t	HY-8-102-0.5/2t
2.5t-5t	HY-8-102-2.5/5t
1K-4KSE	BY-8-104-1/4KSE
5K-10K	BY-8-104-5/10K

### Features:

Easy installation, automatically centralized with steel ball, good self-aligning ability. Mainly used for platform scales and other electronic weighing devices.



### Outline Dimension mm(inch)

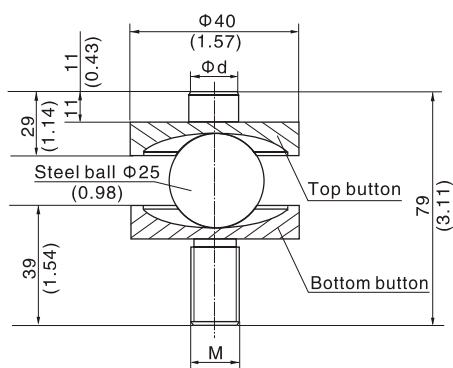

Dimension Capacity	Φd	M
0.5t-2t 1K-4KSE	12 (0.47)	M12 × 1.75
2.5t-5t 5K-10K	18 (0.71)	M18 × 1.5